

# DZC 12001/12002

DZC 12001 and 12002 are horizontal anchor windlasses with single or double gypsies. Electric or hydraulic versions are available providing a max. pull of 12000 kgs. It has a gypsy for chains 30, 32, 34, 36, 38, 40 or 42 mm stud-link.

|  | DZC 12001E / 12002E                | DZC 12001H / 12002H            |
|--|------------------------------------|--------------------------------|
| Drive  | AC Electric Motor (210-440V, 3 ph) | Hydraulic Motor                |
| Max. cont. Pull  | 9500 kg (30000W - 30 min)          | 12000 kg (30 min)              |
| Max. pull  | 12000 kg (30000W - 2 min)          | 13200 kg (2 min)               |
| Haulage speed  | 12 m/min.                          | 11 m/min.                      |
| Gypsy for chain  | 30-32-34-36-38-40-42 Stud-link     | 30-32-34-36-38-40-42 Stud-link |
| Approximate weight   |                                    |                                |
| Current draw (at max. cont.pull)/Hyd. pressure - Oil flow (on motor) | 42.5A (22000W) - 55A (30000W)      | 210 bar - 105 lt/min           |
| Motor power  | 22000W - 30000W (400V - 50hz)      |                                |



[datahidrolik.com](http://datahidrolik.com)

## DZC 12002 E / P-36L/22

### Drum

|         |                                    |
|---------|------------------------------------|
| 12001   | 1 gypsy 1 warping drum             |
| 12002   | 2 gypsies 2 warping drums          |
| 12001-1 | 1 gypsy 1 rope drum 1 warping drum |

### Drive

|   |                        |
|---|------------------------|
| E | E. Motor driven        |
| H | Hydraulic motor driven |

### Gypsy & Drum Position

|   |  |
|---|--|
| L | As the drawing<br>In the opposite side |
|---|--|

### Material

|    |                 |
|----|-----------------|
| Kr | Stainless steel |
| P  | Steel           |

### Chain Type / Size

|     |                 |
|-----|-----------------|
| 30L | 30 mm Stud-link |
| 32L | 32 mm Stud-link |
| 34L | 34 mm Stud-link |
| 36L | 36 mm Stud-link |
| 38L | 38 mm Stud-link |
| 40L | 40 mm Stud-link |
| 42L | 42 mm Stud-link |

### E. Motor

|    |                       |
|----|-----------------------|
| 22 | 22 kW 380VAC E. Motor |
| 30 | 30 kW 380VAC E. Motor |

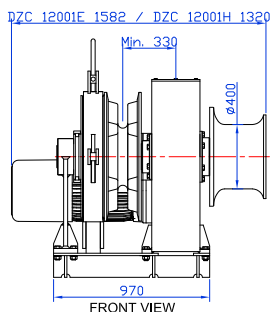

DZC 12001

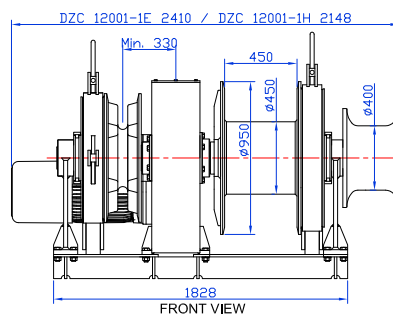
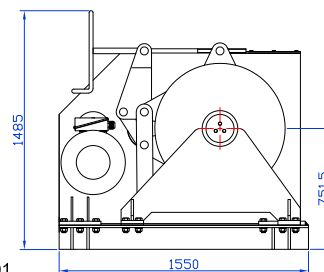

DZC 12001-1

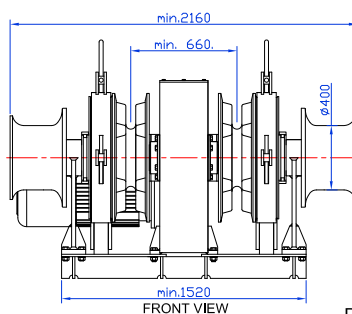
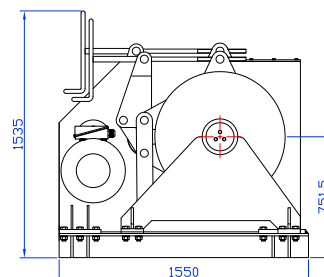

DZC 12002

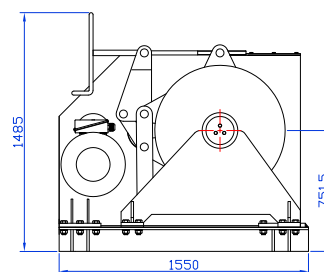

## FEATURES

Gypsies are equipped with both clutch and band brake to allow independent operation of gypsy and warping drum.

Chain can be dropped by loosening band brake.

Gypsy is engaged by means of dog clutch.

Electric motor driven models are equipped with torque limiting coupling for over load protection.

Body is steel and covered with polyurethane paint.

High strength drive shaft and brake screw are stainless steel.

DOL starter for electric motor driven models.

Increased strength with vertical supports at the ends of main shaft which also allows to arrange the distance between two gypsies.

Hardened steel gears in oil bath.

## OPTIONS

AC electric motor drive.

Hydraulic motor drive with single or double speed.

Single or double gypsy.

For single gypsy models, right and left versions available.

Single or double mooring drum with brake and clutch.

Starter with frequency converter.

Remote hydraulic released gypsy brake.

Foundation to be welded on deck.